

Datasheet

Gas Discharge Tube (GDT)

Series / Models	2RL-8TH Series
Product Code	10.10.85.XXXX
Version	A2
Date	2026-04-28
File Number	SP-GDT-275

Version History

Version	Date	Page	Description	Author
A0	2025-03-11	/	Initial draft	Xia Wu
A1	2025-07-29	Page 7	Update Dimensions	Xia Wu
A2	2026-04-28	Page 6	Delete Electrical Characteristics for 2R-8TH(2000~3600V)	Xia Wu

Gas Discharge Tube (GDT)

2RL-8TH Series

Description

Gas discharge tubes (GDTs) are generally in a high insulation resistance state, equivalent to an open circuit, which has almost no impact on the normal operation of the circuit. When transient overvoltage occurs in the circuit and the voltage amplitude exceeds the breakdown voltage of the GDT, the gas inside the GDT is ionized, causing the GDT to quickly conduct and limit the overvoltage to a lower level, thereby protecting electronic devices or circuit components connected in parallel from high voltage impact damage. After the overvoltage disappears, the GDT immediately returns to a high insulation resistance state, and the circuit resumes normal operation.

2RL-8TH is a small size ultra-thin radial lead GDT with advanced manufacturing process and epoxy resin coating on its surface, which has excellent performance. Epoxy coating provides excellent electrical insulation, mechanical protection and moisture resistance, making it suitable for use in harsh environments. Radial lead structure is easy to install and connect on PCB and other equipment, and has unique advantages over axial lead in some PCB layouts. The ultra-thin design meets some application scenarios that require strict space size, such as compact electronic devices. The low residual voltage design can effectively limit the residual voltage level after overvoltage and reduce the risk of subsequent circuit component damage. It is suitable for precision circuits with low voltage fluctuation tolerance.



Electrical symbol

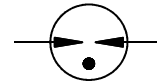

Features

- I Patented technology
- I Occupy smaller PCB area
- I Excellent response to fast rising transients
- I Stable breakdown voltage
- I GHz working frequency
- I 8/20 μ s Impulse current capability: 10KA / 5KA / 4KA
- I Non-Radioactive
- I Ultra Low capacitance (<3pF)
- I GDT diameter: Φ 8mm

Applications

- I Telecom CPE
- I Communication equipment
- I Surge Protective Devices
- I High density PCB assemblies



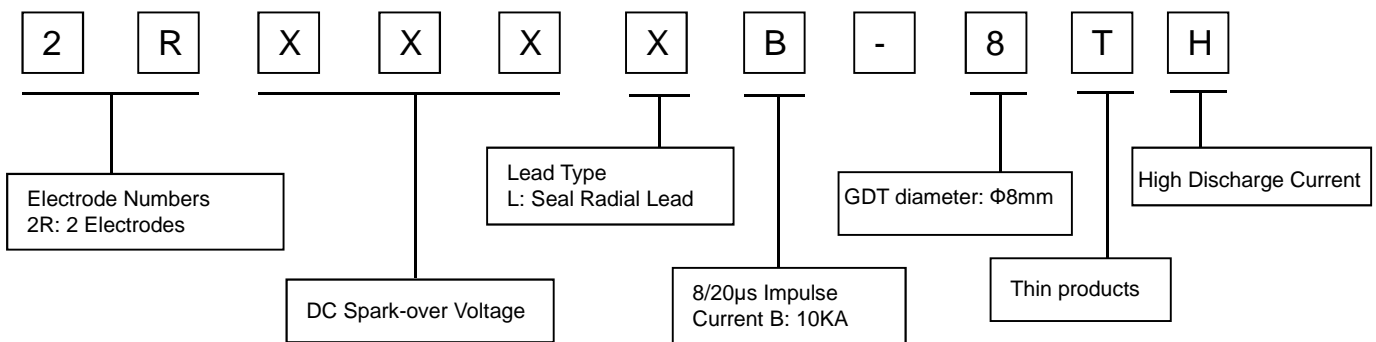



Part Number Code



Gas Discharge Tube (GDT)







2RL-8TH Series

Electrical Characteristics

Model		2R090LB-8TH	2R230LB-8TH	2R350LB-8TH	2R470LB-8TH	Units
DC Spark-over Voltage ^{1) 2)}	at 100V/S	90±30%	230±30%	350±30%	470±30%	V
Impulse Spark-over Voltage	at 100V/μS	<500	<600	<500	<600	V
	at 1KV/μS	<600	<700	<600	<700	V
Front of wave spark-over voltage	at 1.2/50μS, 6 kV	<800	<850	<750	<850	V
Service life (According to IEC 61643-311)						
Nominal impulse discharge current	8/20μS ±5 times	10	10	10	10	KA
Max. impulse discharge current	8/20μS 1 time	20	20	20	20	KA
Impulse discharge current	10/350μS 2 times	2	2	2	2	KA
Alternating Discharge Current	50Hz, 1S 10 times	5	5	5	5	A
Impulse life	10/1000μS 300 times	100	100	100	100	A
Glow Voltage	at 10mA	~60	~135	~135	~160	V
Arc Voltage	at 1A	~10	~15	~15	~18	V
Insulation Resistance		>1	>1	>1	>1	GΩ
Insulation Resistance Measuring Voltage		50	100	100	100	V _{bc}
Capacitance	at 1MHz	<3	<3	<3	<3	pF
Weight		~1.1	~1.1	~1.1	~1.1	g
Operation and storage temperature		-40~+125	-40~+125	-40~+125	-40~+125	°C
Climatic category (IEC60068-1)		40/125/21	40/125/21	40/125/21	40/125/21	
Certifications ³⁾						
	UL1449	E508408	◎	◎	◎	◎
	 EN 61643-311 IEC 61643-311	R 50655662	--	--	--	--
Marking, Laser marking		RUILON 2R090LB-8TH 	RUILON 2R230LB-8TH 	RUILON 2R350LB-8TH 	RUILON 2R470LB-8TH 	
Surface treatment	Body	Epoxy resin coating, red				
	Leads	Tin plated				
Moisture sensitivity level ⁴⁾		1				

Gas Discharge Tube (GDT)

2RL-8TH Series

Model		2R600LB-8TH	2R800LB-8TH	2R1000L-8TH	2R1500L-8TH	Units
DC Spark-over Voltage ^{1) 2)}	at 100V/S	600±20%	800±20%	1000±20%	1500±20%	V
Impulse Spark-over Voltage	at 100V/μS	<750	<1000	<1200	<1800	V
	at 1KV/μS	<850	<1100	<1300	<2000	V
Front of wave spark-over voltage	at 1.2/50 μs, 6 kV	<1000	<1300	<1500	<2300	V
Service life (According to IEC 61643-311)						
Nominal impulse discharge current	8/20μs ±5 times	10	10	10	10	KA
Max. impulse discharge current	8/20μs 1 time	20	20	20	20	KA
Impulse discharge current	10/350μs 2 times	2	2	2	2	KA
Alternating discharge current	50Hz, 1S 10 times	5	5	5	5	A
Impulse life	10/1000μS 300 times	100	100	100	100	A
	1.2/50μS, 2Ω 40 times	20	20	20	20	KV
	1.2/50μS, 12Ω 80 times	20	20	20	20	KV
Glow Voltage	at 10mA	~180	~180	~200	~200	V
Arc Voltage	at 1A	~18	~18	~18	~20	V
AC withstand voltage	at 5mA 1minute	--	--	500	750	V
Insulation Resistance		>1	>1	>1	>1	GΩ
	Insulation Resistance Measuring Voltage	100	100	100	100	V _{DC}
Capacitance	at 1MHz	<3	<3	<3	<3	pF
Weight		~1.1	~1.1	~1.1	~1.1	g
Operation and storage temperature		-40~+125	-40~+125	-40~+125	-40~+125	°C
Climatic category (IEC60068-1)		40/125/21	40/125/21	40/125/21	40/125/21	
Certifications ³⁾						
	UL1449	E508408	◎	◎	◎	◎
	 EN 61643-311 IEC 61643-311	R 50655662	--	--	◎	--
Marking, Laser marking		RUILON 2R600LB-8TH 	RUILON 2R800LB-8TH 	RUILON 2R1000L-8TH  	RUILON 2R1500L-8TH 	
Surface treatment	Body	Epoxy resin coating, red				
	Leads	Tin plated				
Moisture sensitivity level ⁴⁾		1				

¹⁾ At delivery AQL 0.65 level II, DIN ISO 2859.

²⁾ In ionized mode.

³⁾ “ ” indicates that the product has passed the certification, “--” indicates that the product is not certified.

⁴⁾ Tests according to JEDEC J-STD-020.

Terms in accordance with ITU-T Rec. K.12, IEC 61643-311, GB/T18802.311, GB/T 9043.

Gas Discharge Tube (GDT)

2RL-8TH Series

Dimensions

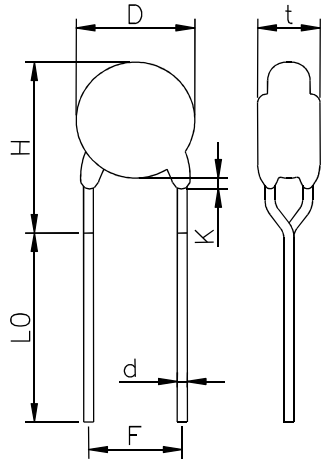

Symbol	Millimeters	Inches
D	Φ10 Max	Φ0.394 Max
d	Φ0.8±0.05	Φ0.031±0.002
F	7.5±0.5	0.295±0.020
H	15 Max	0.591 Max
K	3 Max	0.118 Max
L0	15 Min	0.591 Min
t	7 Max	0.276 Max

Packaging Information

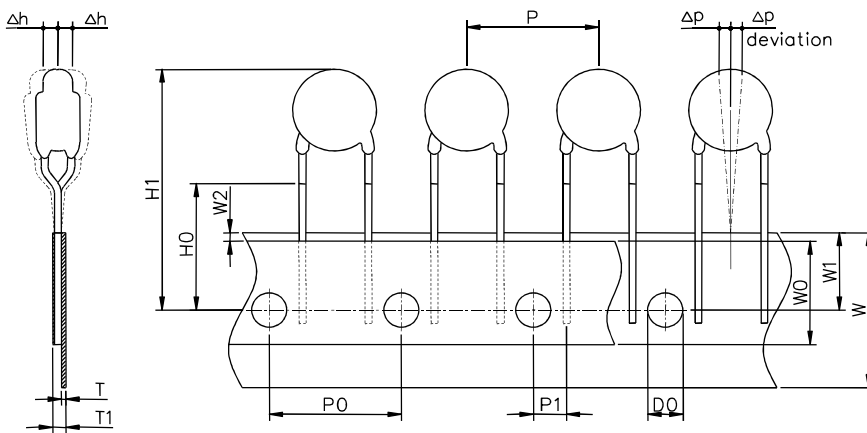



➔ Direction of Unreeling

Packing and dimensions according to IEC 60286-2

Symbol	Millimeters	Inches
P	15.0±1.0	0.591±0.039
P0	15.0±0.3	0.591±0.012
P1	3.75±0.7	0.148±0.028
H0	16.0+2/-0	0.630+0.079/-0
H1	46.5 Max	1.831 Max
T	0.9 Max	0.035Max
T1	1.7 Max	0.067 Max
W	18+1/-0.5	0.709+0.039/-0.020
W0	5.0 Min	0.197 Min
W1	9+0.75/-0.5	0.354+0.030/-0.020
W2	3.0 Max	0.118 Max
D0	Φ4±0.2	Φ0.157±0.008
Δh	2.0 Max	0.079 Max
Δp	1.3 Max	0.051 Max

Gas Discharge Tube (GDT)

2RL-8TH Series

	Inner Box	Carton
Size	335 × 265 × 42mm	550 × 350 × 240mm
Quantity	MPQ/MOQ: 1 Inner Box=1,000pcs	1Carton=10 Inner Box=10,000pcs
Photos		

Soldering Parameters - Wave soldering (Thru-Hole Devices)

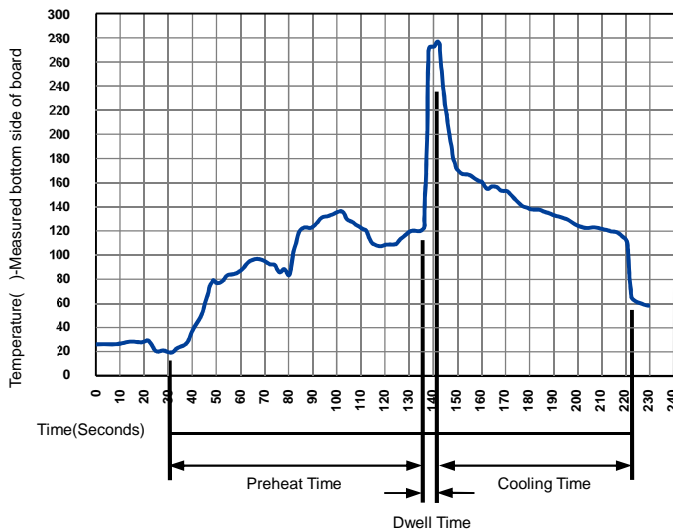

Wave Soldering Condition		Pb-Free assembly
Preheat	Temperature Min	100°C
	Temperature Max	150°C
	Time (Min to Max)	60-180 Seconds
Solder Pot Temperature		280°C Max
Solder Dwell Time		2-5 Seconds

Gas Discharge Tube (GDT)

2RL-8TH Series

Construction

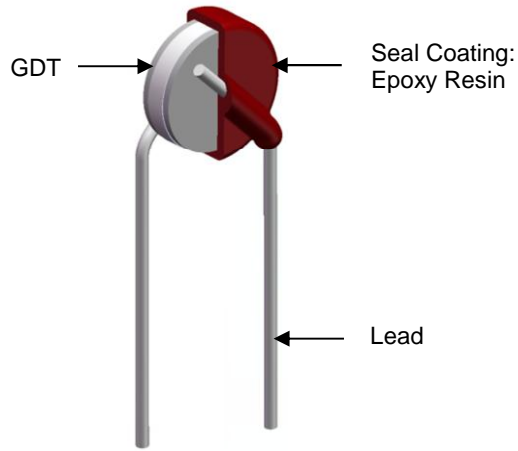

Application Circuit

Use for AC1500V withstand voltage

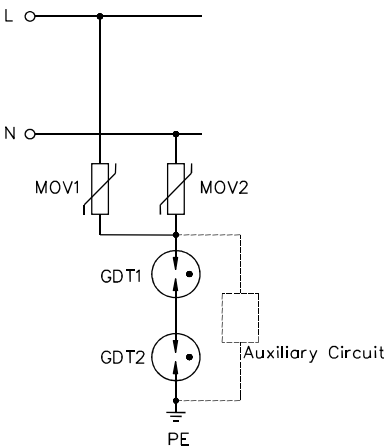

Symbol	Model
MOV1	14D471
MOV2	14D471
GDT1	2R1500L-8TH
GDT2	2R1500L-8TH

Electrical Characteristics (With auxiliary circuit)		
DC Spark-over Voltage	at 100V/S	2400~3600V
Impulse Spark-over Voltage	at 100V/μS	<2000V
	at 1KV/μS	<2300V
Front of wave spark-over voltage	at 1.2/50 μs, 6 kV	<2500V
AC withstand voltage	at 5mA 1minute	1500V
Service life		
Nominal impulse discharge current	8/20μs ±5 times	10KA
Maximum discharge current	8/20μs 1 times	15KA
Alternating Discharge Current	50Hz, 1S 10 times	3KA

1.2/50 μs, 6 kV Waveform (+)

1.2/50 μs, 6 kV Waveform (-)



Terms and definitions

NO.	Item	Definitions
1	Gas discharge tube(GDT)	Gap, or several gaps, in an enclosed discharge medium, other than air at atmospheric pressure, designed to protect apparatus or personnel, or both, from high transient voltages. Also referred to as "gas tube surge arrester".
2	DC Spark-over Voltage	The voltage at which the gas discharge tube sparks over with slowly increasing d.c. voltage.
3	Impulse Spark-over Voltage	The highest voltage which appears across the terminals of a gas discharge tube in the period between the application of an impulse of given wave-shape and the time when current begins to flow.
4	Impulse discharge current 8/20μs	Current impulse with a nominal virtual front time of 8 μ s and a nominal time to half-value of 20 μ s.
5	Impulse discharge current 10/350μs	Current impulse with a nominal virtual front time of 10 μ s and a nominal time to half-value of 350 μ s.
6	1,2/50 voltage impulse	Voltage impulse with a nominal virtual front time of 1,2 μ s and a nominal time to half-value of 50 μ s.
7	Maximum continuous operating voltage U_c	Maximum r.m.s. voltage, which may be continuously applied to the GDT's mode of protection.
8	Nominal discharge current I_n	Crest value of the current through the GDT having a current waveshape of 8/20.
9	Maximum discharge current I_{max}	Crest value of a current through the SPD having an 8/20 waveshape and magnitude according to the manufacturers specification. I_{max} is equal to or greater than I_n .
10	Impulse discharge current for class I test I_{imp}	Crest value of a discharge current through the SPD with specified charge transfer Q and specified energy W/R in the specified time.
11	Follow current I_f	Peak current supplied by the electrical power system and flowing through the SPD after a discharge current impulse.
12	Insulation Resistance	Insulation resistance shall be measured from each terminal to every other terminal of the GDT. The test is performed with DC50V when normal spark-over Voltage 70~150V, others with DC100V.
13	Capacitance	The capacitance shall be measured once at 1 MHz between all terminals unless otherwise specified.
14	Class I tests	Tests carried out with the impulse discharge current I_{imp} , with an 8/20 current impulse with a crest value equal to the crest value of I_{imp} , and with a 1,2/50 voltage impulse.
15	Class II tests	Tests carried out with the nominal discharge current I_n , and the 1,2/50 voltage impulse.

Cautions

- I Do not operate gas discharge tubes in power supply networks, whose maximum operating voltage exceeds the minimum spark-over voltage of the gas discharge tubes.
- I Gas discharge tubes may become hot in the event of longer periods of current stress (burn risk). In the event of overload the connectors may fail or the component may be destroyed.
- I Gas discharge tubes must be handled with care and must not be dropped.
- I Do not continue to use damaged gas discharge tubes.
- I The electrical characteristics described in this datasheet are only typical characteristics, and all of these characteristics have been confirmed through testing and inspection. If the customer's usage requirements are different from this or have special requirements, please contact Ruilongyuan Electronics Co., Ltd. If protection failure or circuit damage occurs as a result, our company is not responsible for it.
- I Ruilongyuan Electronics Co., Ltd. always strives to improve our products. Consequently, the products described in this datasheet may be updated from time to time, and the corresponding product specifications may also be updated accordingly. So, before or at the time of placing your order, please check to what extent the product descriptions and specifications contained in this publication are still applicable. Ruilongyuan Electronics Co., Ltd. still reserves the right to cease production and delivery of products. Consequently, we cannot guarantee that all products listed in this datasheet will always be available. The above provisions do not apply to individual agreements with customers for specific products.
- I Ruilongyuan Electronics Co., Ltd. models may have different product codes. Different product code representations are due to the use of different production processes, but do not affect their respective product specifications.